

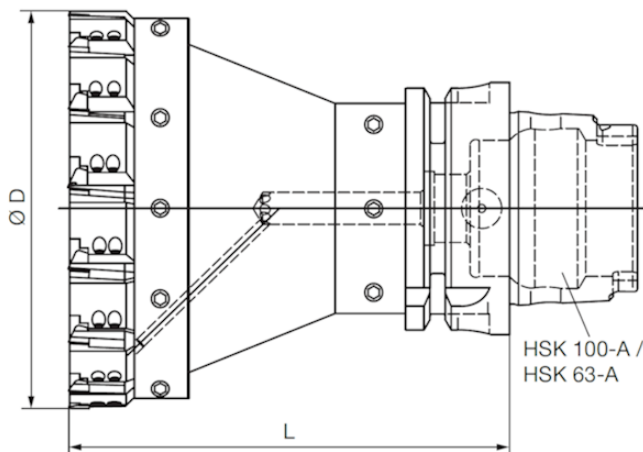

## HPC milling cutters

for finish machining

**Standard range with maximum number of cutting edges for cutting depths up to max. 2 mm**

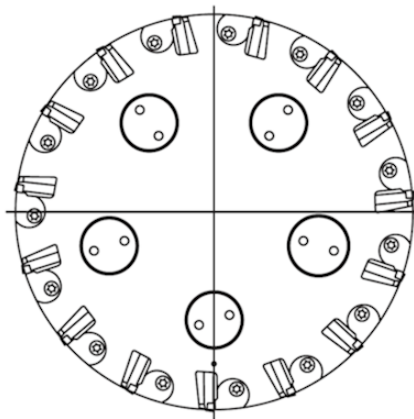

Part nr. 20004	1 MOL BY HOLLFELDER GÖHRING		2 MOL BY HOLLFELDER GÖHRING on request				
Code	Drawing nr.	Diameter/mm	teeth	L/mm	max.rev./min	Shank	Weight(kg)
<b>for lower spindle power</b>							
63,106	Q9933-6300 1063R	63	9	100	31,000	HSK 63-A	1.9
80,106	Q9933-8000 1163R	80	12	110	28,000	HSK 63-A	2.7
100,106	Q9933-1000 1163R	100	15	110	24,000	HSK 63-A	3.7
125,106	Q9933-1250 1263R	125	18	123	20,000	HSK 63-A	5.5
160,106	Q9933-1600 1263R	160	24	123	15,000	HSK 63-A	7.7

Part nr. 20004							
Code	Drawing nr.	Diameter/mm	teeth	L/mm	max.rev./min	Shank	Weight(kg)
<b>for lower spindle power</b>							
63,108	Q9933-6300 1010R	63	9	100	31,000	HSK 100-A	3.2
80,108	Q9933-8000 1110R	80	12	110	28,000	HSK 100-A	4.2
100,108	Q9933-1000 1110R	100	15	110	24,000	HSK 100-A	5.7
125,108	Q9933-1250 1210R	125	18	123	20,000	HSK 100-A	7.7
160,108	Q9933-1600 1210R	160	24	123	15,000	HSK 100-A	10

We reserve the right to make technical changes.