

H Indexable inserts precision ground
for boring bars starting from 5 mm working diameter

Insert W 1733-..... L/R*
Carbide / carbide coated / PCD 10

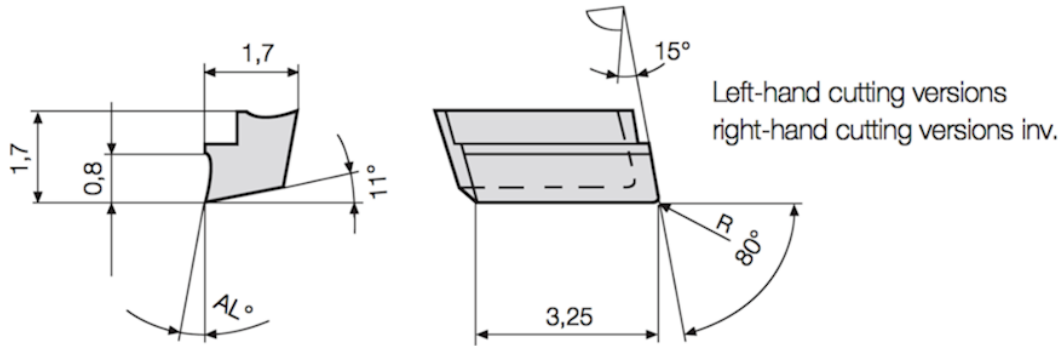

				Part nr. 20128	Part nr. 20129	Part nr. 20130	Part nr. 20131	Part nr. 20132	Part nr. 20133
				uncoated			coated		
Code	Drawing nr.	R	AL°	P10	P40	K10	H02	H06	H26
17,330	W1733-0008 1000L	0.05	10	●	●	●	●	●	●
17,331	W1733-0208 1000L	0.2	10	●	●	●	●	●	●
17,332	W1733-0008 1620L	0.05	16	○	○	●	●	○	
17,333	W1733-0208 1620L	0.2	16	○	○	●	●	○	

				Part nr. 20226	Part nr. 20227	Part nr. 20228	Part nr. 20229	Part nr. 20230	Part nr. 20231
				uncoated			coated		
Code	Drawing nr.	R	AL°	P10	P40	K10	H02	H06	H26
17,330	W1733-0008 1000R	0.05	10	●	●	●	●	●	●
17,331	W1733-0208 1000R	0.2	10	●	●	●	●	●	●
17,332	W1733-0008 1620R	0.05	16	○	○	●	●	○	●
17,333	W1733-0208 1620R	0.2	16	○	○	●	●	○	●

				Part nr. 20140
Code	Drawing nr.	R	AL°	PCD10
17,330	W1733-0000 0000L	0.05	0	●
17,331	W1733-0200 0000L	0.2	0	●
17,332	W1733-0400 0000L	0.4	0	●

				Part nr. 20232
Code	Drawing nr.	R	AL°	PCD10
17,330	W1733-0000 0000R	0.05	0	●
17,331	W1733-0200 0000R	0.2	0	●
17,332	W1733-0400 0000R	0.4	0	●

*Please note: Left-hand boring bars have to be fitted with right-hand inserts and right-hand boring bars with left-hand inserts!

● ex stock ○ on request

We reserve the right to make technical changes.