



Toolholders with HSK-tapers shank DIN 69893-1

Universal arbor DIN 69882-2

Concentricity from the taper to the holding part < 0.005

Base-body balanced, G 2.5 - 8,000 r.p.m.

HSK-A63 with internal coolant supply, for tools with coolant channel to the cutting edge



HSK - A

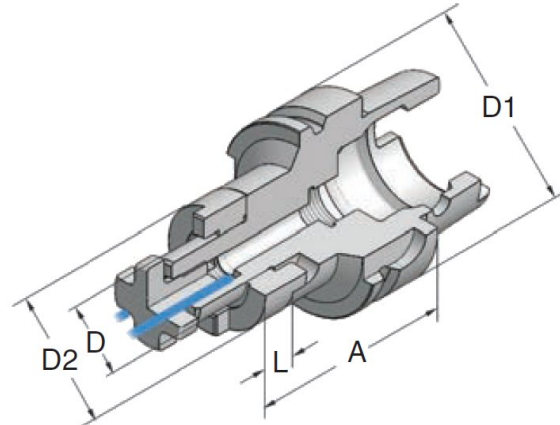

HSK - A 63

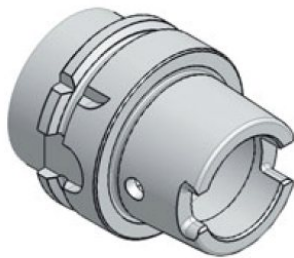

Art.-Nr.	Type	D1	A	D	D2	L
63.11.16.4	HSK-A63x16x 60	63	60	16	32	10
63.11.16.42	HSK-A63x16x100	63	100	16	32	10
63.11.16.43	HSK-A63x16x160	63	160	16	32	10
63.11.22.4	HSK-A63x22x 60	63	60	22	40	12
63.11.22.42	HSK-A63x22x100	63	100	22	40	12
63.11.22.43	HSK-A63x22x160	63	160	22	40	12
63.11.27.4	HSK-A63x27x 60	63	60	27	48	12
63.11.27.42	HSK-A63x27x100	63	100	27	48	12
63.11.27.43	HSK-A63x27x160	63	160	27	48	12
63.11.32.4	HSK-A63x32x 60	63	60	32	58	14
63.11.32.42	HSK-A63x32x100	63	100	32	58	14
63.11.32.43	HSK-A63x32x160	63	160	32	58	14
63.11.40.4	HSK-A63x40x 70	63	70	40	70	14
HSK - A 100						
100.11.16.42	HSK-A100x16x100	100	100	16	32	10
100.11.16.43	HSK-A100x16x160	100	160	16	32	10
100.11.22.42	HSK-A100x22x100	100	100	22	40	12
100.11.22.43	HSK-A100x22x160	100	160	22	40	12
100.11.27.42	HSK-A100x27x100	100	100	27	48	12
100.11.27.43	HSK-A100x27x160	100	160	27	48	12
100.11.32.42	HSK-A100x32x100	100	100	32	58	14
100.11.40.42	HSK-A100x40x100	100	100	40	70	14

We reserve the right to make technical changes.