



Toolholders with HSK-tapers shank DIN 69893-1

Shell mill adaptors DIN 69882-3

Concentricity from the taper to the holding part < 0.005

Base-body balanced, G 2.5 - 20,000 r.p.m.

HSK-A100 - G2.5 - 15,000 r.p.m.

With internal coolant supply for tools with coolant channel to the cutting edge

HSK-E with internal coolant supply for tools with coolant channel to the cutting edge

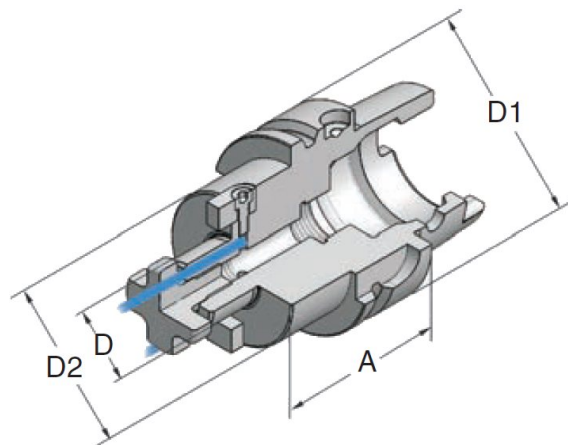

HSK - A

HSK - A 40

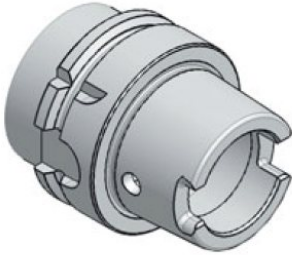
	Art.-Nr.	Type	D1	A	D	D2
	40.11.16.9	HSK-A40x16x 50	40	50	16	38
40.11.22.9	HSK-A40x22x 50	40	50	22	44	
HSK - A 50						
50.11.16.9	HSK-A50x16x 50	50	50	16	39	
50.11.22.9	HSK-A50x22x 50	50	50	22	42	
50.11.27.9	HSK-A50x27x 55	50	55	27	60	
HSK - A 63						
63.11.16.9	HSK-A63x16x 50	63	50	16	39	
63.11.16.92	HSK-A63x16x100	63	100	16	39	
63.11.22.9	HSK-A63x22x 50	63	50	22	49	
63.11.22.92	HSK-A63x22x100	63	100	22	49	
63.11.27.9	HSK-A63x27x 60	63	60	27	60	
63.11.27.92	HSK-A63x27x100	63	100	27	60	
63.11.32.9	HSK-A63x32x 60	63	60	32	68	
63.11.32.92	HSK-A63x32x100	63	100	32	68	
63.11.40.9	HSK-A63x40x 60	63	60	40	88	

We reserve the right to make technical changes.

Shell mill adaptors DIN 69882-3

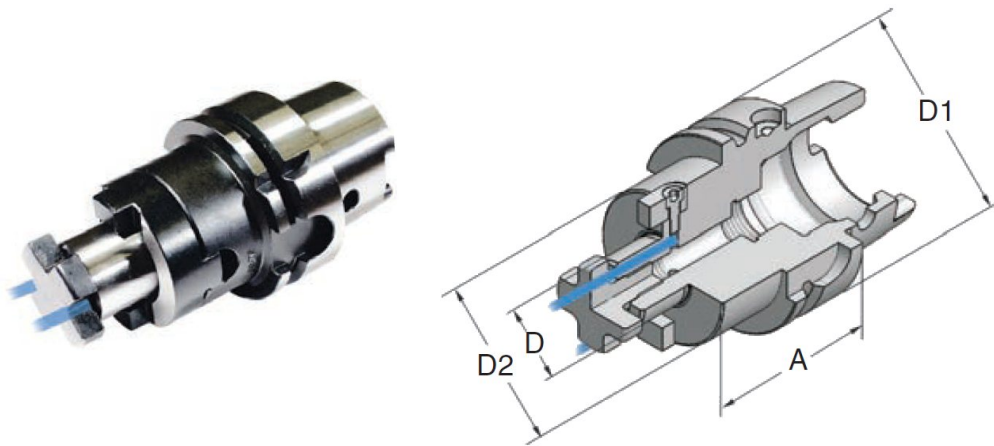

HSK - A

HSK - A 100

	Art.-Nr.	Type	D1	A	D	D2
		100.11.16.9	HSK-A100x16x 60	100	60	16
	100.11.16.92	HSK-A100x16x100	100	100	16	39
	100.11.16.93	HSK-A100x16x160	100	160	16	39
	100.11.22.9	HSK-A100x22x 60	100	60	22	49
	100.11.22.92	HSK-A100x22x100	100	100	22	49
	100.11.22.93	HSK-A100x22x160	100	160	22	49
	100.11.27.9	HSK-A100x27x 60	100	60	27	60
	100.11.27.92	HSK-A100x27x100	100	100	27	60
	100.11.27.93	HSK-A100x27x160	100	160	27	60
	100.11.32.9	HSK-A100x32x 60	100	60	32	68
	100.11.32.92	HSK-A100x32x100	100	100	32	68
	100.11.32.93	HSK-A100x32x160	100	160	32	68
	100.11.40.9	HSK-A100x40x 60	100	60	40	89
	100.11.40.92	HSK-A100x40x100	100	100	40	89
	100.11.40.93	HSK-A100x40x160	100	160	40	89

We reserve the right to make technical changes.

Shell mill adaptors DIN 69882-3

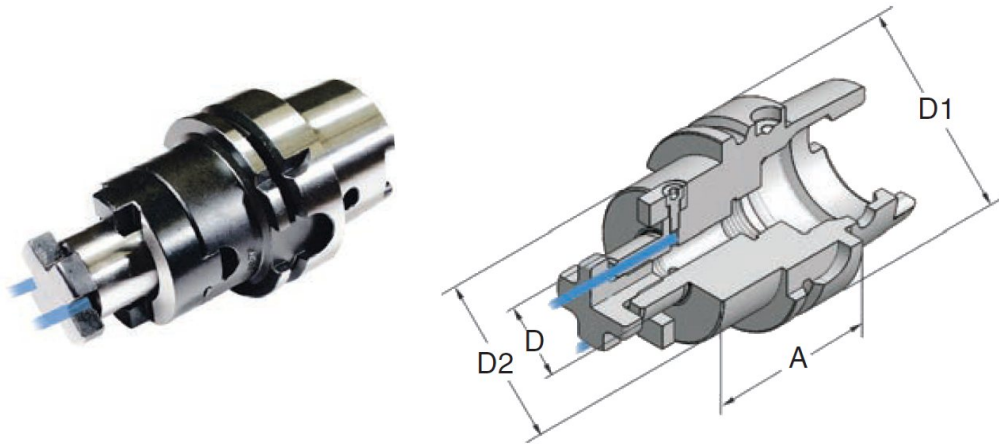

HSK - E

HSK - E 40

	Art.-Nr.	Type	D1	A	D	D2	
	40.12.16.9	HSK-E40x16x 50	40	50	16	38	
	40.12.22.9	HSK-E40x22x 50	40	50	22	44	
	HSK - E 50						
	50.12.16.9	HSK-E50x16x 50	50	50	16	39	
	50.12.22.9	HSK-E50x22x 50	50	50	22	42	
	50.12.27.9	HSK-E50x27x 55	50	55	27	60	
	HSK - E 63						
	63.12.16.9	HSK-E63x16x 50	63	50	16	39	
	63.12.22.9	HSK-E63x22x 50	63	50	22	49	
	63.12.27.9	HSK-E63x27x 60	63	60	27	60	
	63.12.32.9	HSK-E63x32x 60	63	60	32	68	

HSK - F

HSK - F 63

	Art.-Nr.	Type	D1	A	D	D2
	63.13.16.9	HSK-F63x16x 50	63	50	16	39
	63.13.22.9	HSK-F63x22x 50	63	50	22	49
	63.13.27.9	HSK-F63x27x 60	63	60	27	60
	63.13.32.9	HSK-F63x32x 60	63	60	32	68

We reserve the right to make technical changes.