



Toolholders with HSK-tapers shank DIN 69893-1

Holders for straight shank tools with lockable coolant borings DIN 69882-4 (Weldon DIN 1835 B)

Concentricity from the taper to the holding part < 0.005

Base-body balanced, G 2.5 - 20,000 r.p.m.

Delivery without tool



HSK - A

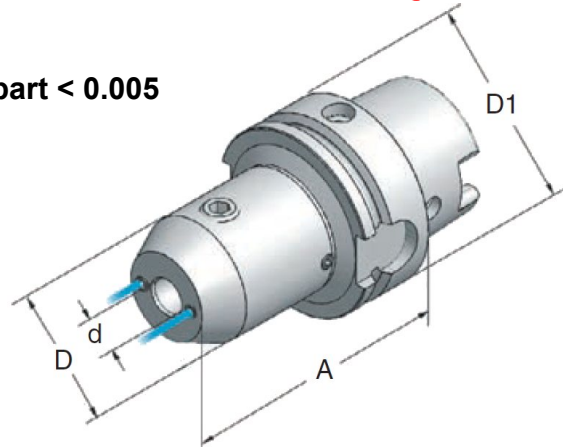

HSK - A 63

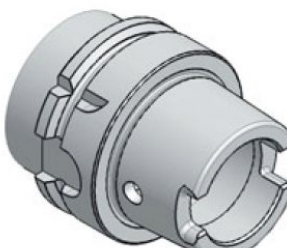
	Art.-Nr.	Type	D1	A	d	D
		63.11.06.67	HSK-A63x06x 80	63	80	6
	63.11.06.672	HSK-A63x06x120	63	120	6	25
	63.11.08.67	HSK-A63x08x 80	63	80	8	28
	63.11.08.672	HSK-A63x08x120	63	120	8	28
	63.11.10.67	HSK-A63x10x 80	63	80	10	35
	63.11.10.672	HSK-A63x10x120	63	120	10	35
	63.11.12.67	HSK-A63x12x 80	63	80	12	42
	63.11.12.672	HSK-A63x12x120	63	120	12	42
	63.11.14.67	HSK-A63x14x 80	63	80	14	44
	63.11.16.67	HSK-A63x16x 80	63	80	16	48
	63.11.16.672	HSK-A63x16x120	63	120	16	48
	63.11.20.67	HSK-A63x20x 80	63	80	20	52
	63.11.20.672	HSK-A63x20x120	63	120	20	52
	63.11.25.67	HSK-A63x25x110	63	110	25	63
	63.11.32.67	HSK-A63x32x110	63	110	32	72

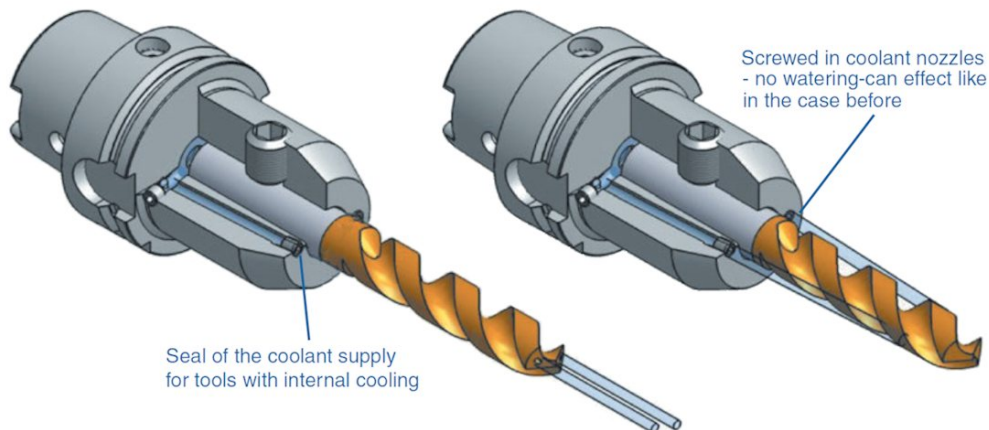

We reserve the right to make technical changes.