



**Toolholders with HSK-tapers shank DIN 69893-1**

**Shrinking chucks with lockable coolant borings DIN 69882-8**

Best possible coolant supply through coolant channels  
Concentrated coolant supply up to 20,000 r.p.m. to the cutting edge

Base-body balanced, G 2.5 - 20,000 r.p.m.

Delivery without tool

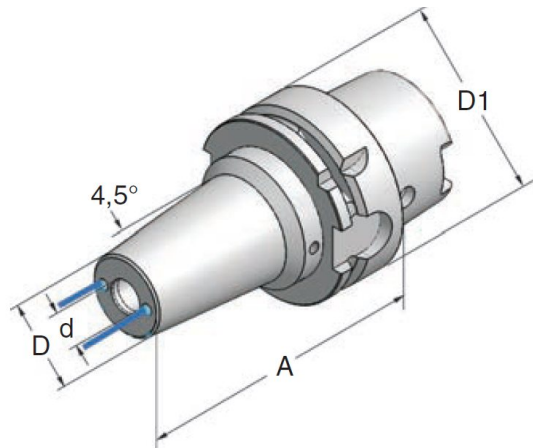

**HSK - A**

**HSK - A 63**



Art.-Nr.	Type	D1	A	d	D
63.11.08.36	HSK-A63x08Sx 80	63	80	8	25
63.11.08.362	HSK-A63x08Sx130	63	130	8	25
63.11.08.363	HSK-A63x08Sx160	63	160	8	25
63.11.10.36	HSK-A63x10Sx 85	63	85	10	27
63.11.10.362	HSK-A63x10Sx130	63	130	10	27
63.11.10.363	HSK-A63x10Sx160	63	160	10	27
63.11.12.36	HSK-A63x12Sx 90	63	90	12	29
63.11.12.362	HSK-A63x12Sx130	63	130	12	29
63.11.12.363	HSK-A63x12Sx160	63	160	12	29
63.11.14.36	HSK-A63x14Sx 90	63	90	14	31
63.11.14.362	HSK-A63x14Sx130	63	130	14	31
63.11.16.36	HSK-A63x16Sx 95	63	95	16	33
63.11.16.362	HSK-A63x16Sx130	63	130	16	33
63.11.16.363	HSK-A63x16Sx160	63	160	16	33
63.11.18.36	HSK-A63x18Sx 95	63	95	18	35
63.11.18.362	HSK-A63x18Sx130	63	130	18	35
63.11.20.36	HSK-A63x20Sx100	63	100	20	37
63.11.20.362	HSK-A63x20Sx130	63	130	20	37
63.11.25.36	HSK-A63x25Sx100	63	100	25	44

We reserve the right to make technical changes.

## Shrinking chucks with **lockable coolant borings** DIN 69882-8

Best possible coolant supply through coolant channels  
Concentrated coolant supply up to 20,000 r.p.m. to the cutting edge

Base-body balanced, G 2.5 - 20,000 r.p.m.

Delivery without tool

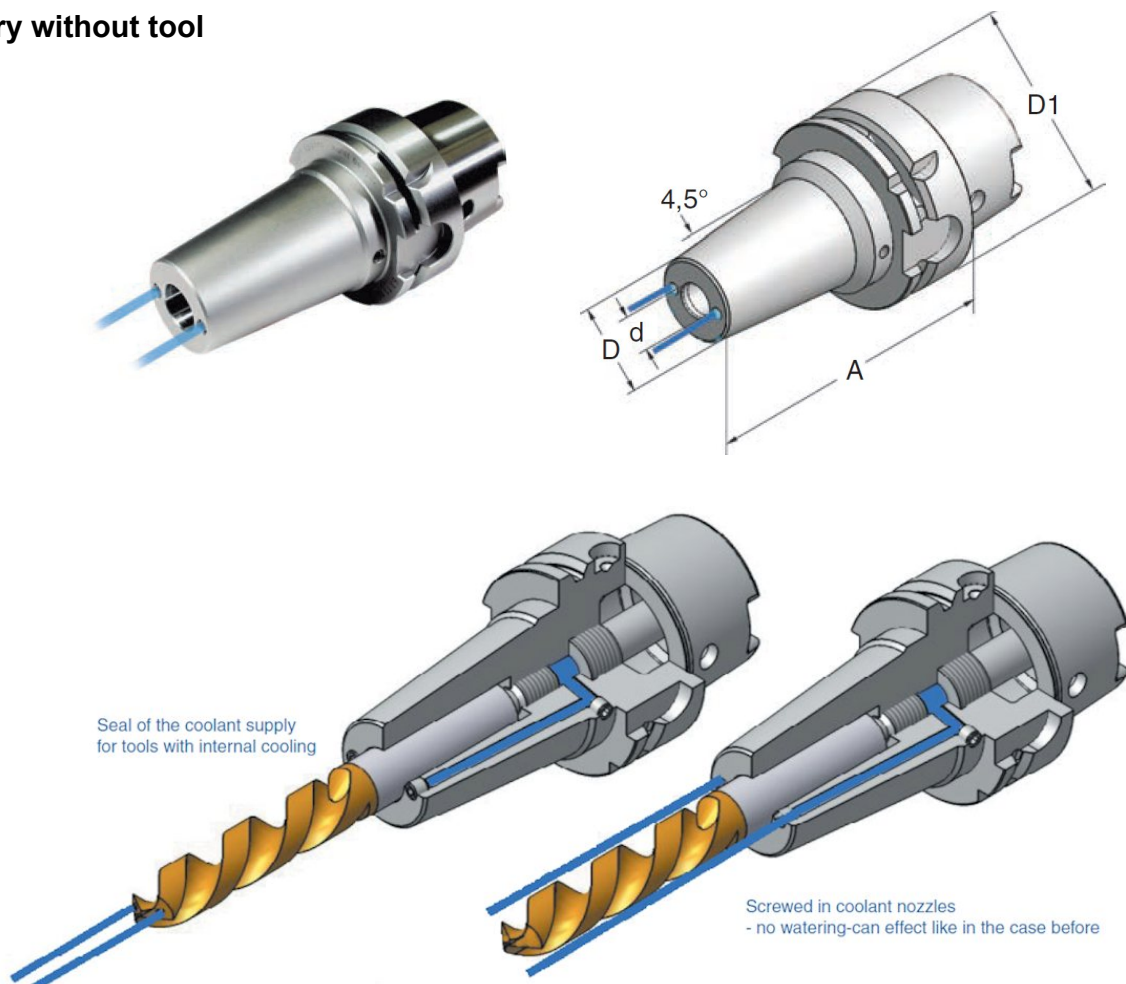

We reserve the right to make technical changes.