



**Toolholders with HSK-tapers shank ISO 12164-3**

HSK-T multi-turning-toolholders **with internal coolant**

- for clamping holders with coolant channels **directly to the cutting edge**

- for ISO-clamping holders **with claw clamping for best possible coolant supply**

- **coolant pressure up to 100 bar**

Delivery without tool

One turning-toolholder - four possibilities:  
left - right - forehead - overhead

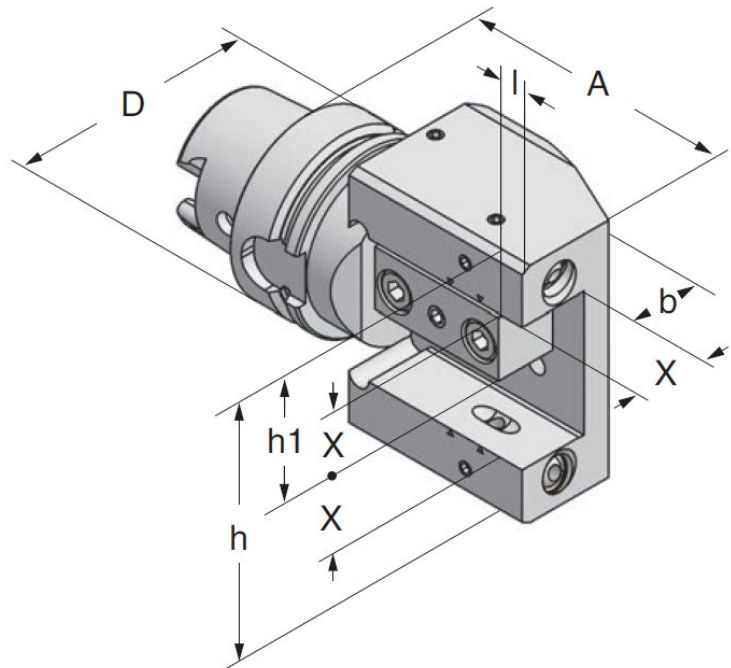

**HSK - T 40**

Art.-Nr.	Type	D	A	X	h	h1	b	l
40.11.10.043	HSK-T 40x10x 70	40	70	10	55	27.5	10	-
Coolant supply only with coolant nozzle								
<b>HSK - T 63</b>								
63.11.20.043	HSK-T 63x20x112	63	112	20	80	40	31.5	10
63.11.25.043	HSK-T 63x25x112	63	112	25	90	45	31.5	10
<b>HSK - T 100</b>								
100.11.25.043	HSK-T100x25x125	100	125	25	90	45	31.5	-

We reserve the right to make technical changes.

## Toolholders with HSK-tapers shank ISO 12164-3

### HSK-T multi-turning-toolholders 90° with internal coolant

- for clamping holders with coolant channels **directly to the cutting edge**
- for ISO-clamping holders **with claw clamping for best possible coolant supply**
- **coolant pressure up to 100 bar**

Delivery without tool

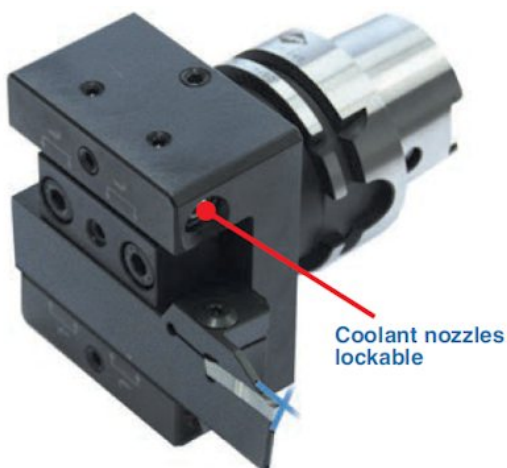

One turning-toolholder - four possibilities:  
left - right - forehead - overhead

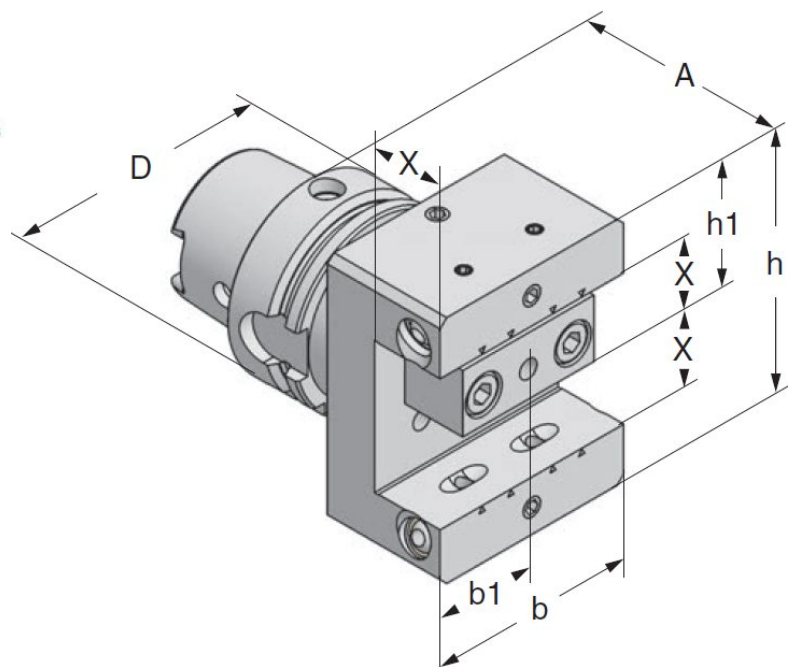

### HSK - T 63

Art.-Nr.	Type	D	A	X	h	h1	b	l
63.11.20.046	HSK-T 63x20x90°	63	85	20	80	40	35	70
63.11.25.046	HSK-T 63x25x90°	63	85	25	90	45	35	70
HSK - T 100								
100.11.25.046	HSK-T100x25x90°	100	125	25	90	45	40	60

We reserve the right to make technical changes.

## Toolholders with HSK-tapers shank ISO 12164-3

### HSK-T multi-turning-toolholders 45° with internal coolant

- for clamping holders with coolant channels **directly to the cutting edge**
- for ISO-clamping holders **with claw clamping for best possible coolant supply**
- **coolant pressure up to 100 bar**

Delivery without tool

One turning-toolholder - four possibilities:  
left - right - forehead - overhead

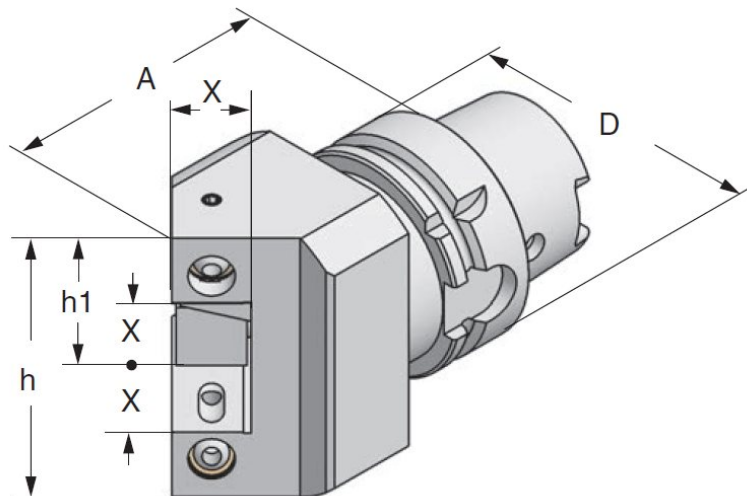

### HSK - T 63

Art.-Nr.	Type	D	A	X	h	h1
63.11.20.045	HSK-T 63x20x45°	63	93	20	80	40
63.11.25.045	HSK-T 63x25x45°	63	97	25	90	45
HSK - T 100						
100.11.25.045	HSK-T100x25x45°	100	128	25	88	44

We reserve the right to make technical changes.