



ISO Taper-toolholders BT-P

Blank



BT-P30

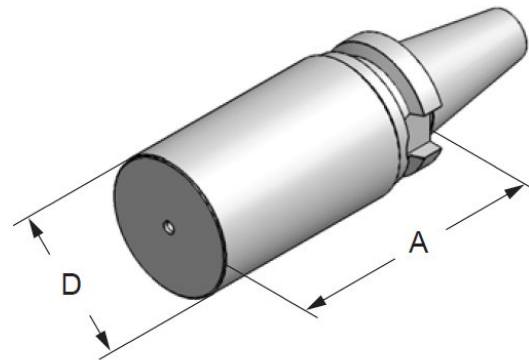

BT-P40

Art.-Nr.	Type	A	D	Art.-Nr.	Type	A	D
30.06.100.046	BT-P30xø46x100	100	46	40.06.200.064	BT-P40xø64x200	200	64
30.06.150.046	BT-P30xø46x150	150	46				

We reserve the right to make technical changes.

Retention knobs MAS BT30x45°/ 60°



Retention knobs

Art.-Nr.	Type	D1	D2	D3	L	L1	α	d	Form
30.12.4	BT30x45°	11.0	7.0	M12	43	23	45°	-	B
30.12.4-C	BT30x45° iK	11.0	7.0	M12	43	23	45°	$\varnothing 2.5$	A
30.12.41	BT30x60°	11.0	7.0	M12	43	23	60°	-	B
30.12.41-C	BT30x60° iK	11.0	7.0	M12	43	23	60°	$\varnothing 2.5$	A
30.12.43-C	BT30x45° iK Fanuc	11.0	8.0	M12	43	23	45°	$\varnothing 4$	A
30.12.44-C	BT30x60° iK Brother	11.0	7.5	M12	43	23	60°	$\varnothing 4$	A

Retention knob SK30x45° for Fanuc machines

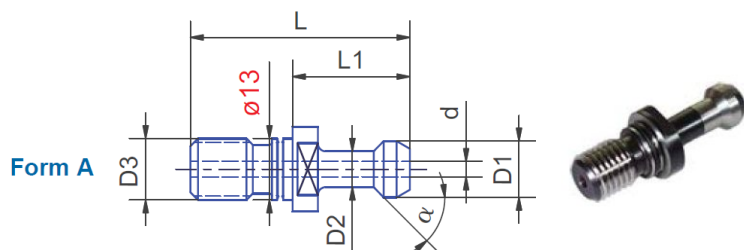

Retention knobs

Art.-Nr.	Type	D1	D2	D3	L	L1	α	d	Form
30.12.1-F	SK30x45° iK Fanuc	11.0	8.0	M12	43.6	23.6	45°	$\varnothing 4$	A

We reserve the right to make technical changes.