

## ISO Taper-toolholders

### Collet chucks DIN 6391 for collets DIN 6388 / ISO 10897

Taper angle AT3, Concentricity from the taper to the holding part < 0.005

Base-body balanced, SK30/BT30 G 2.5 - 25,000 r.p.m.  
SK40/BT40 G 2.5 - 20,000 r.p.m.  
SK50/BT50 G 2.5 - 15,000 r.p.m.

Collets on inquiry

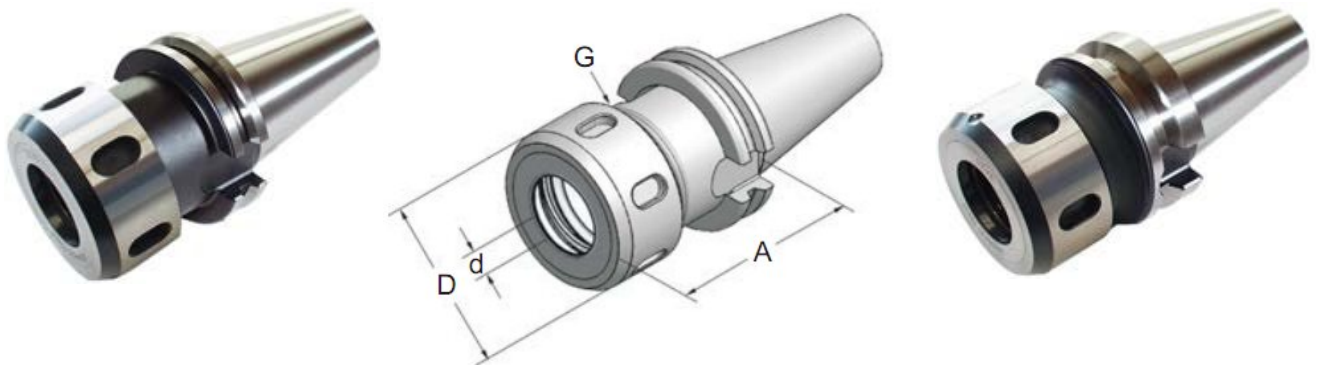

**DIN 69871**

**MAS BT**

Art.-Nr.	Type	A	d	D	G	Art.-Nr.	Type	A	d	D	G
						30.05.16.1	BT30xOZ16x 70-AD	70	1-16	43	M33x1.5
40.01.16.10	SK40xOZ16x 70-AD+B	70	1-16	43	M33x1.5	40.05.16.1	BT40xOZ16x 70-AD	70	1-16	43	M33x1.5
40.01.16.12	SK40xOZ16x100-AD+B	100	1-16	43	M33x1.5						
40.01.25.10	SK40xOZ25x 70-AD+B	70	2-25	60	M48x2.0	40.05.25.1	BT40xOZ25x 70-AD	70	2-25	60	M48x2.0
40.01.25.12	SK40xOZ25x100-AD+B	100	2-25	60	M48x2.0						
40.01.32.10	SK40xOZ32x 90-AD+B	90	4-32	72	M60x2.5	40.05.32.1	BT40xOZ32x 80-AD	80	4-32	72	M60x2.5
50.01.25.10	SK50xOZ25x100-AD+B	100	2-25	60	M48x2.0	50.05.25.1	BT50xOZ25x100-AD	100	2-25	60	M48x2.0
50.01.32.10	SK50xOZ32x100-AD+B	100	4-32	72	M60x2.5	50.05.32.1	BT50xOZ32x100-AD	100	4-32	72	M60x2.5

We reserve the right to make technical changes.