

ISO Taper-toolholders

Shell mill adaptors for facing cutters DIN 6357

Taper angle AT3, Concentricity from the taper to the holding part < 0.005

Base-body balanced, SK30/BT30 G 2.5 - 25,000 r.p.m.

SK40/BT40 G 2.5 - 20,000 r.p.m.

SK50/BT50 G 2.5 - 15,000 r.p.m.

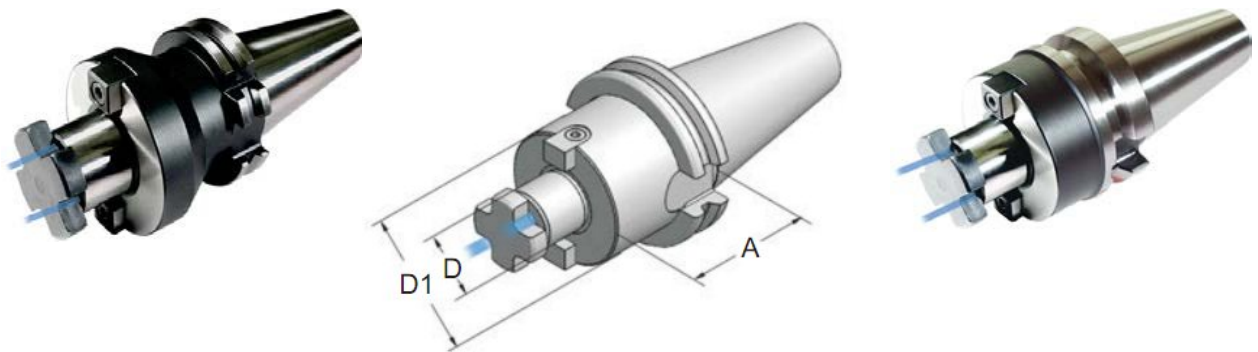

DIN 69871

MAS BT

| Art.-Nr. | Type | A | D | D1 | Art.-Nr. | Type | A | D | D1 |
|------------|-------------------|----|----|-----|------------|-------------------|----|----|-----|
| | | | | | 30.05.16.9 | BT30x16x40-AD+C | 40 | 16 | 39 |
| | | | | | 30.05.22.9 | BT30x22x40-AD+C | 40 | 22 | 48 |
| | | | | | 30.05.27.9 | BT30x27x40-AD+C | 40 | 27 | 48 |
| 40.01.16.9 | SK40x16x50-AD+B+C | 50 | 16 | 39 | 40.05.16.9 | BT40x16x50-AD+B+C | 50 | 16 | 39 |
| 40.01.22.9 | SK40x22x50-AD+B+C | 50 | 22 | 49 | 40.05.22.9 | BT40x22x50-AD+B+C | 50 | 22 | 49 |
| 40.01.27.9 | SK40x27x50-AD+B+C | 50 | 27 | 60 | 40.05.27.9 | BT40x27x50-AD+B+C | 50 | 27 | 60 |
| 40.01.32.9 | SK40x32x60-AD+B+C | 60 | 32 | 68 | 40.05.32.9 | BT40x32x60-AD+B+C | 60 | 32 | 68 |
| 40.01.40.9 | SK40x40x60-AD+B+C | 60 | 40 | 88 | 40.05.40.9 | BT40x40x60-AD+B+C | 60 | 40 | 88 |
| 50.01.22.9 | SK50x22x60-AD+B+C | 60 | 22 | 49 | 50.05.22.9 | BT50x22x60-AD+B+C | 60 | 22 | 49 |
| 50.01.27.9 | SK50x27x60-AD+B+C | 60 | 27 | 60 | 50.05.27.9 | BT50x27x60-AD+B+C | 60 | 27 | 60 |
| 50.01.32.9 | SK50x32x60-AD+B+C | 60 | 32 | 68 | 50.05.32.9 | BT50x32x60-AD+B+C | 60 | 32 | 68 |
| 50.01.40.9 | SK50x40x70-AD+B+C | 70 | 40 | 88 | 50.05.40.9 | BT50x40x60-AD+B+C | 60 | 40 | 88 |
| 50.01.60.9 | SK50x60x70-AD+B+C | 70 | 60 | 128 | 50.05.60.9 | BT50x60x80-AD+B+C | 80 | 60 | 128 |

We reserve the right to make technical changes.