

## ISO Taper-toolholders **without groove**

### Collet chucks DIN 6391 **without groove** for collets ER/ESX DIN 6388 / ISO 10897

Taper angle AT3, Concentricity from the taper to the holding part < 0.005

**SK-30** G 2.5 - 25,000 U/min. or U < 1 gmm

**SK-40** G 2.5 - 20,000 U/min. or U < 1 gmm

Collets on inquiry

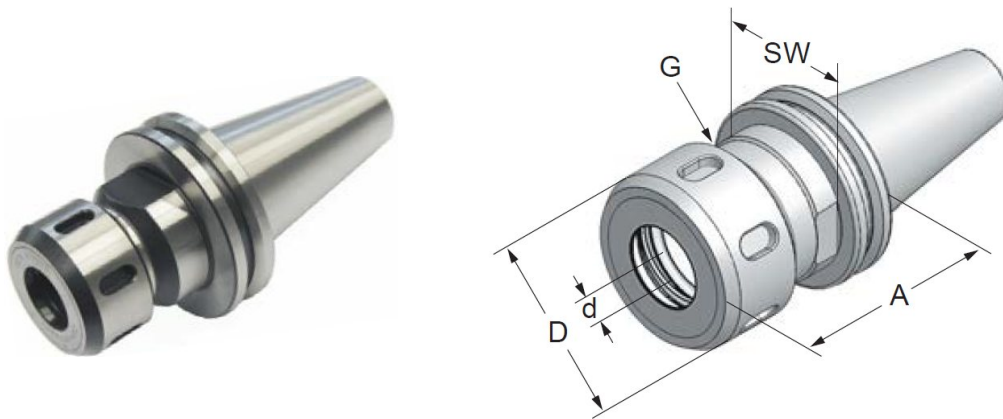

### DIN 69871

Art.-Nr.	Type	Collet	d	D	A	SW	G
30.01.25.01	SK30xOZ25x70-AD	444E / 462E	2 - 25	60	70	36	M48x2.0
40.01.16.01	SK40xOZ16x70-AD	410E / 415E	2 - 16	43	70	36	M33x1.5
40.01.25.01	SK40xOZ25x70-AD	444E / 462E	2 - 25	60	70	46	M48x2.0

We reserve the right to make technical changes.

## Collet chucks DIN 6391 **without groove** for collets ER/ESX DIN 6499 / ISO 15488

Taper angle AT3, Concentricity from the taper to the holding part < 0.005

**SK-30** G 2.5 - 25,000 U/min. or U < 1 gmm

**SK-40** G 2.5 - 20,000 U/min. or U < 1 gmm

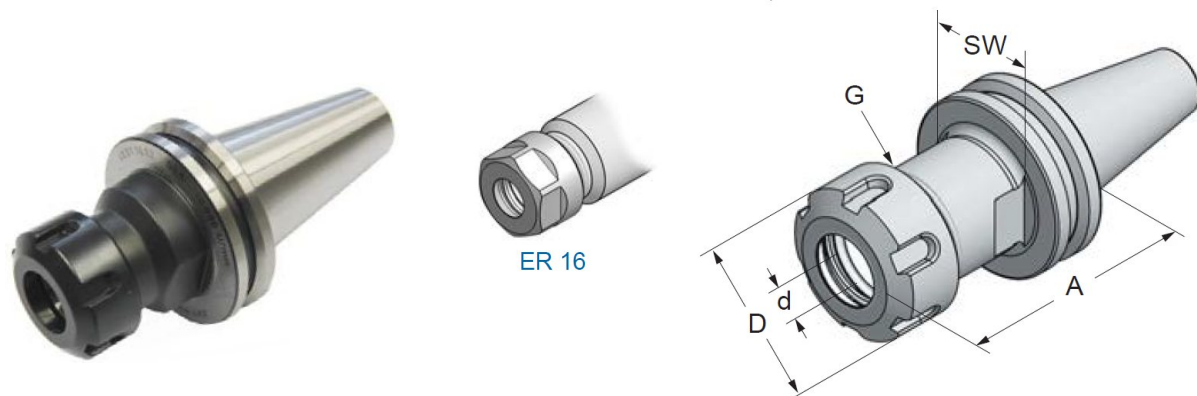

### DIN 69871

Art.-Nr.	Type	Collet	d	D	A	SW	G
30.01.10.02	SK30xER16x 70-AD	ER16 / 462E	1 - 10	28	70	24	M22x1.5
30.01.10.022	SK30xER16x100-AD	ER16 / 426E	1 - 10	28	100	24	M22x1.5
30.01.16.02	SK30xER25x 70-AD	ER25 / 430E	2 - 16	42	70	27	M32x1.5
30.01.16.022	SK30xER25x100-AD	ER25 / 430E	2 - 16	42	100	27	M32x1.5
30.01.20.02	SK30xER32x 70-AD	ER32 / 470E	3 - 20	50	70	36	M40x1.5
30.01.20.022	SK30xER32x100-AD	ER32 / 470E	3 - 20	50	100	36	M40x1.5
30.01.26.02	SK30xER40x 70-AD	ER40 / 472E	4 - 26	63	70	41	M50x1.5
40.01.16.02	SK40xER25x 70-AD	ER25 / 430E	2 - 16	42	70	36	M32x1.5
40.01.20.02	SK40xER32x 70-AD	ER32 / 470E	3 - 20	50	70	36	M40x1.5
40.01.26.02	SK40xER40x 70-AD	ER40 / 472E	4 - 26	63	70	46	M50x1.5

We reserve the right to make technical changes.