

## ISO Taper-toolholders

### Shrinking chucks **POWER-FLASH** high-speed

Best possible coolant supply through coolant channels in the boring. Concentrated coolant supply up to 20,000 r.p.m. to the cutting edge

ø3-ø5 - 2 channels, ø6-ø32 - 3 channels

BT30 G 2.5 - 25,000 r.p.m.

SK40/BT40 G 2.5 - 20,000 r.p.m.



SK 40 DIN 69871, MAS BT 30 + 40, ø3 - ø32



Delivery without tool

#### Stop screw

Art.-Nr.	d	M
368100	ø6	M 8x1
369100	ø8	M 8x1
370100	ø10	M10x1
371100	ø12	M10x1
372100	ø16	M10x1
373100	ø20	M10x1

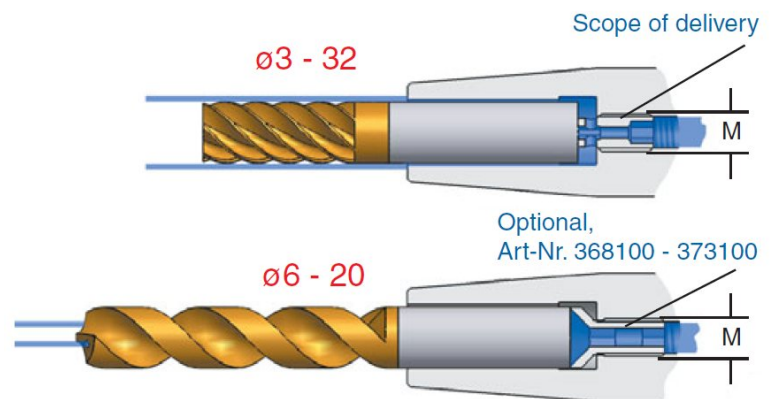

We reserve the right to make technical changes.

## Shrinking chucks **POWER-FLASH** high-speed

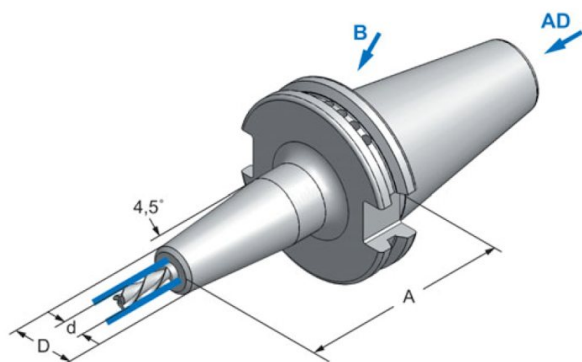

**DIN 69871**

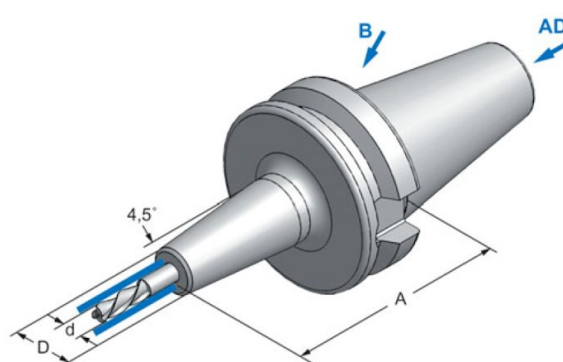

**MAS BT**

Art.-Nr.	Type	A	d	D	M	Art.-Nr.	Type	A	d	D	M
40.01.03.37	SK40x03SCx 80-AD+B	80	3	10	M6	30.05.03.37	BT30x03SCx 70-AD	70	3	10	M6
40.01.04.37	SK40x04SCx 80-AD+B	80	4	11	M6	30.05.04.37	BT30x04SCx 70-AD	70	4	11	M6
40.01.05.37	SK40x05SCx 80-AD+B	80	5	14	M8x1	30.05.05.37	BT30x05SCx 70-AD	70	5	14	M8x1
40.01.06.37	SK40x06SCx 80-AD+B	80	6	16	M8x1	30.05.06.37	BT30x06SCx 70-AD	70	6	21	M8x1
40.01.08.37	SK40x08SCx 80-AD+B	80	8	21	M8x1	30.05.08.37	BT30x08SCx 70-AD	70	8	21	M8x1
40.01.10.37	SK40x10SCx 80-AD+B	80	10	24	M10x1	30.05.10.37	BT30x10SCx 70-AD	70	10	24	M10x1
40.01.12.37	SK40x12SCx 80-AD+B	80	12	24	M10x1	30.05.12.37	BT30x12SCx 70-AD	70	12	24	M10x1
40.01.16.37	SK40x16SCx 80-AD+B	80	16	26	M10x1	30.05.16.37	BT30x16SCx 70-AD	70	16	26	M10x1
40.01.20.37	SK40x20SCx 80-AD+B	80	20	33	M10x1	30.05.20.37	BT30x20SCx 70-AD	70	20	33	M10x1
40.01.25.37	SK40x25SCx100-AD+B	100	25	44	M10x1						
40.01.32.37	SK40x32SCx100-AD+B	100	32	44	M10x1	40.05.03.37	BT40x03SCx 80-AD+B	80	3	10	M6
						40.05.04.37	BT40x04SCx 80-AD+B	80	4	11	M6
						40.05.05.37	BT40x05SCx 80-AD+B	80	5	14	M8x1
						40.05.06.37	BT40x06SCx 80-AD+B	80	6	16	M8x1
						40.05.08.37	BT40x08SCx 80-AD+B	80	8	21	M8x1
						40.05.10.37	BT40x10SCx 80-AD+B	80	10	24	M10x1
						40.05.12.37	BT40x12SCx 80-AD+B	80	12	24	M10x1
						40.05.16.37	BT40x16SCx 80-AD+B	80	16	26	M10x1
						40.05.20.37	BT40x20SCx 80-AD+B	80	20	33	M10x1
						40.05.25.37	BT40x25SCx100-AD+B	100	25	44	M10x1
						40.05.32.37	BT40x32SCx100-AD+B	100	32	44	M10x1

We reserve the right to make technical changes.