

## ISO Taper-toolholders

### Toolholder for coolant- and air supply

Taper angle AT3, Concentricity from the taper to the holding part < 0.005

max. r.p.m. 3,000

Coolant pressure max. 6 bar

Air pressure max. 4 bar

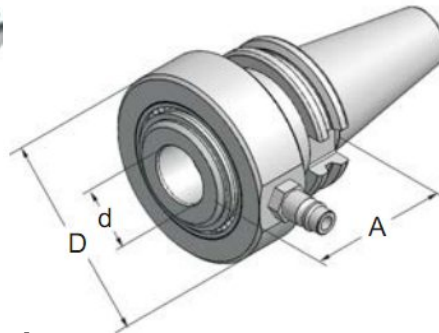

**DIN 69871**

**MAS BT**

Art.-Nr.	Type	A	d	D	Art.-Nr.	Type	A	d	D
40.01.25.68	SK40	65	25	80	40.05.25.68	BT40	58	25	80
40.01.32.68	SK40	65	32	80	40.05.32.68	BT40	58	32	80
50.01.25.68	SK50	65	25	80	50.05.25.68	BT50	65	25	80
50.01.32.68	SK50	65	32	80	50.05.32.68	BT50	65	32	80

### Collet chuck ER32 for coolant- and air supply

max. r.p.m. 3,000

Coolant pressure max. 6 bar

Air pressure max. 4 bar

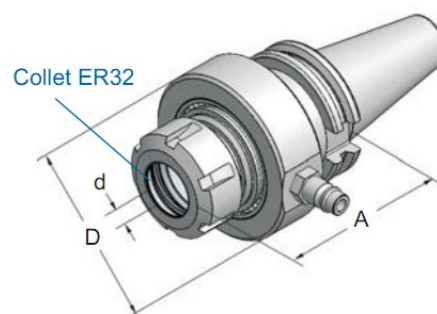

**DIN 69871**

Art.-Nr.	Type	A	d	D
40.01.20.28	SK40	100	2-20	80

We reserve the right to make technical changes.