

ISO Taper-toolholders

Tapping heads for collets ER/ESX

with smooth-action length compensation for pressure and tension



ER 16

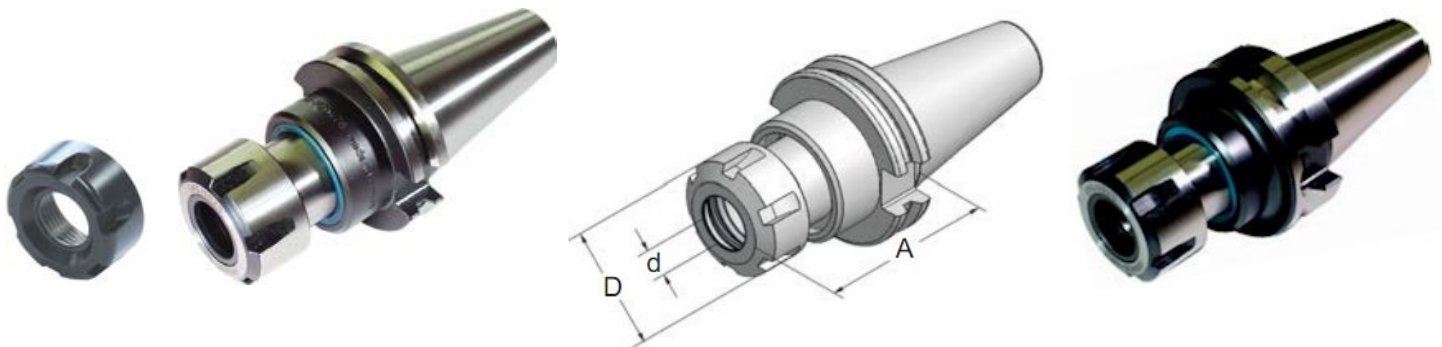

DIN 69871

MAS BT

Art.-Nr.	Type	A	d	D	Art.-Nr.	Type	A	d	D
30.01.12.13	SK30xER16x 70	70	1-10 for M2-M12	28	30.05.20.13	BT30xER25x 93	93	1-10 for M2-M12	42
40.01.12.13	SK40xER16x 65	65	1-10 for M2-M12	28	40.05.12.13	BT40xER16x 65	65	1-10 for M2-M12	28
40.01.20.13	SK40xER25x 78	78	2-16 for M4-M20	42	40.05.20.13	BT40xER25x 82	82	2-16 for M4-M20	42
40.01.24.13	SK40xER32x 94	94	3-20 for M6-M24	50	40.05.24.13	BT40xER32x 98	98	3-20 for M6-M24	50
40.01.33.13	SK40xER40x115	115	4-30 for M8-M33	63	40.05.33.13	BT40xER40x115	115	4-30 for M8-M33	63
45.01.20.13	SK45xER25x 78	78	2-16 for M4-M20	42	45.05.20.13	BT45xER25x 98	98	2-16 for M4-M20	42
45.01.33.13	SK45xER40x102	102	4-30 for M8-M33	63	45.05.33.13	BT45xER40x 95	95	4-30 for M8-M33	63
50.01.20.13	SK50xER25x100	100	2-16 for M4-M20	42	50.05.20.13	BT50xER25x100	100	2-16 for M4-M20	42
50.01.33.13	SK50xER40x102	102	4-30 for M8-M33	63	50.05.33.13	BT50xER40x100	100	4-30 for M8-M33	63

We reserve the right to make technical changes.