

ISO Taper-toolholders

Thread cutting quick-change chucks

with smooth-action length compensation for pressure and tension

The tapping collet has to be ordered separately !

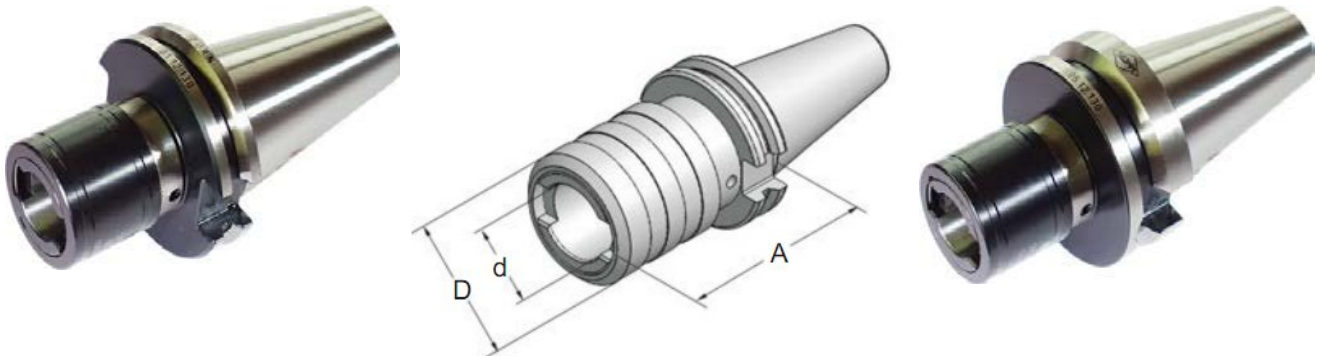

DIN 69871

MAS BT

Art.-Nr.	Type	Size	A	d	D	Art.-Nr.	Type	Size	A	d	D
30.01.12.130	SK30xM3-M12	1	65	19	38	30.05.12.130	BT30xM3-M12	1	62	19	38
40.01.12.130	SK40xM3-M12	1	59	19	38	40.05.12.130	BT40xM3-M12	1	65	19	38
50.01.12.130	SK50xM3-M12	1	50	19	38	50.05.12.130	BT50xM3-M12	1	80	19	38
30.01.20.130	SK30xM8-M20	2	103	31	54	30.05.20.130	BT30xM8-M20	2	95	31	54
40.01.20.130	SK40xM8-M20	2	97	31	54	40.05.20.130	BT40xM8-M20	2	93	31	54
50.01.20.130	SK50xM8-M20	2	82	31	54	50.05.20.130	BT50xM8-M20	2	80	31	54
40.01.33.130	SK40xM14-M33	3	134	48	78	40.05.33.130	BT40xM14-M33	3	126	48	78
50.01.33.130	SK50xM14-M33	3	134	48	78	50.05.33.130	BT50xM14-M33	3	142	48	78

We reserve the right to make technical changes.

Tapping collets with cluth



Size 1 M3-M12

Size 2 M8-M20

Size 3 M14-M33

Art.-Nr.	Type	Art.-Nr.	Type	Art.-Nr.	Type
100035	ø 3.50-M3+M4				
100045	ø 4.50-M4+M6				
100060	ø 6.00-M5+M6+M8				
100070	ø 7.00-M7+M9+M10				
100080	ø 8.00-M8+M11	200080	ø 8.00-M8+M11		
100090	ø 9.00-M9+M12	200090	ø 9.00-M9+M12		
100100	ø10.00-M10	200100	ø10.00-M10		
		200110	ø11.00-M14	300110	ø11.00-M14
		200120	ø12.00-M12+M16	300120	ø12.00-M12+M16
		200140	ø14.00-M18	300140	ø14.00-M18
		200160	ø16.00-M20	300160	ø16.00-M20
				300180	ø18.00-M22+M24
				300200	ø20.00-M27+M30
				300220	ø22.00-M33

We reserve the right to make technical changes.