

ISO Taper-toolholders

Adapter for end mills with thread shank

Taper angle AT3, Concentricity from the taper to the holding part < 0.005

SK40/BT40, Base-body balanced, G 2.5 - 20,000 r.p.m.

Delivery without tool

Special executions on inquiry

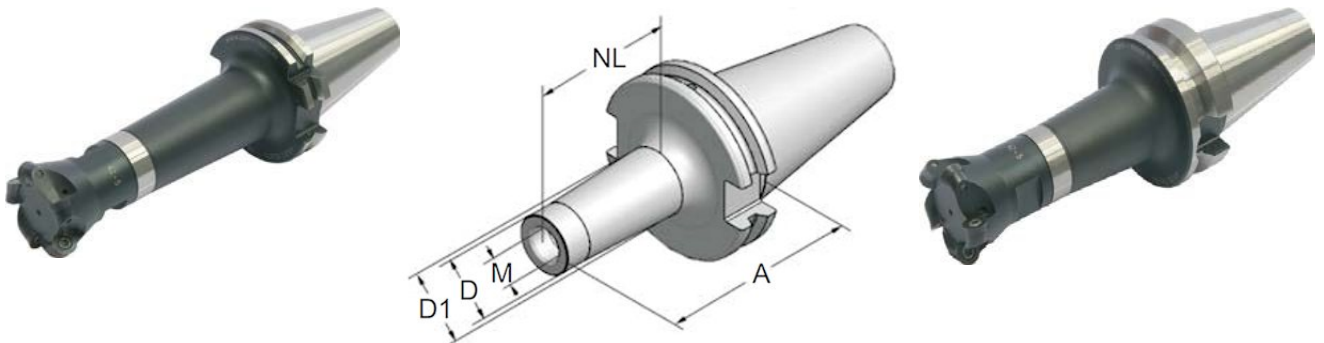

DIN 69871

MAS BT

Art.-Nr.	Type	M	A	NL	D	D1	Art.-Nr.	Type	M	A	NL	D	D1
							30.05.08.025	BT30xM 8x25-AD	8	50	25	13	15
							30.05.08.050	BT30xM 8x50-AD	8	75	50	13	23
							30.05.10.025	BT30xM10x25-AD	10	50	25	18	20
							30.05.10.050	BT30xM10x50-AD	10	75	50	18	25
							30.05.12.025	BT30xM12x25-AD	12	50	25	21	24
							30.05.12.050	BT30xM12x50-AD	12	75	50	21	24
							30.05.16.025	BT30xM16x25-AD	16	50	25	29	34

We reserve the right to make technical changes.

Adapter for end mills with thread shank

Taper angle AT3, Concentricity from the taper to the holding part < 0.005

SK40/BT40, Base-body balanced, G 2.5 - 20,000 r.p.m.

Delivery without tool

Special executions on inquiry

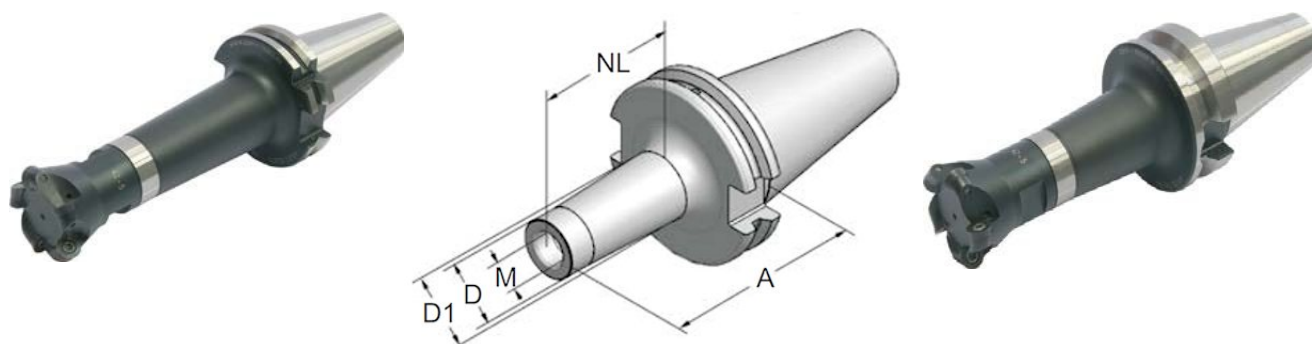

DIN 69871

MAS BT

Art.-Nr.	Type	M	A	NL	D	D1	Art.-Nr.	Type	M	A	NL	D	D1
40.01.06.025	SK40xM 6x25-AD+B	6	52	25	9.7	10	40.05.06.025	BT40xM 6x25-AD+B	6	60	25	9.7	10
40.01.06.050	SK40xM 6x50-AD+B	6	77	50	9.7	20	40.05.06.050	BT40xM 6x50-AD+B	6	85	50	9.7	20
40.01.06.075	SK40xM 6x75-AD+B	6	102	75	9.7	23	40.05.06.075	BT40xM 6x75-AD+B	6	110	75	9.7	23
40.01.08.025	SK40xM 8x25-AD+B	8	52	25	13	15	40.05.08.025	BT40xM 8x25-AD+B	8	60	25	13	15
40.01.08.050	SK40xM 8x50-AD+B	8	77	50	13	23	40.05.08.050	BT40xM 8x50-AD+B	8	85	50	13	23
40.01.08.075	SK40xM 8x75-AD+B	8	102	75	13	23	40.05.08.075	BT40xM 8x75-AD+B	8	110	75	13	23
40.01.10.025	SK40xM10x25-AD+B	10	52	25	18	20	40.05.10.025	BT40xM10x25-AD+B	10	60	25	18	20
40.01.10.050	SK40xM10x50-AD+B	10	77	50	18	25	40.05.10.050	BT40xM10x50-AD+B	10	85	50	18	25
40.01.10.075	SK40xM10x75-AD+B	10	102	75	18	28	40.05.10.075	BT40xM10x75-AD+B	10	110	75	18	28
40.01.12.025	SK40xM12x25-AD+B	12	52	25	21	24	40.05.12.025	BT40xM12x25-AD+B	12	60	25	21	24
40.01.12.050	SK40xM12x50-AD+B	12	77	50	21	24	40.05.12.050	BT40xM12x50-AD+B	12	85	50	21	24
40.01.12.075	SK40xM12x75-AD+B	12	102	75	21	31	40.05.12.075	BT40xM12x75-AD+B	12	110	75	21	31
40.01.16.025	SK40xM16x25-AD+B	16	52	25	29	34	40.05.16.025	BT40xM16x25-AD+B	16	60	25	29	34
40.01.16.050	SK40xM16x50-AD+B	16	77	50	29	34	40.05.16.050	BT40xM16x50-AD+B	16	85	50	29	34
40.01.16.075	SK40xM16x75-AD+B	16	102	75	29	34	40.05.16.075	BT40xM16x75-AD+B	16	110	75	29	34

We reserve the right to make technical changes.