

Toolholders for CNC machines DIN 69880 / DIN ISO 10889

Radial-axial toolholders form B1/C1

Coolant supply external

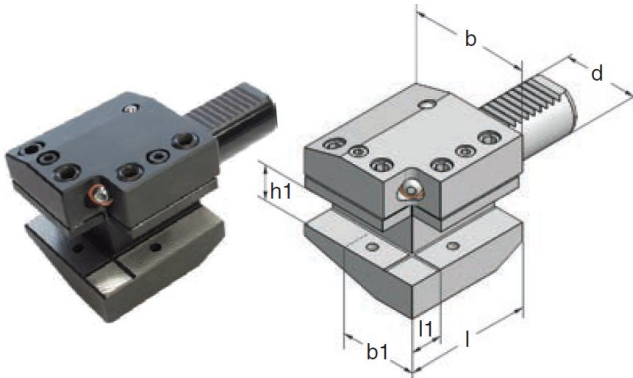

Art.-Nr.	Type	d	b	b1	h1	l	l1
20.16.150	B1/C1-20x16x	50	20	65	40.0	16	50
30.20.150	B1/C1-30x20x	70	30	70	35.0	20	70
50.32.150	B1/C1-50x32x120	50	100	50.0	32	120	25
60.32.150	B1/C1-60x32x135	60	125	62.5	32	135	30
40.25.150/180	B1/C1+B4/C4-40x25x100*						
*Double tooling							

Radial-axial toolholders form B2/C2

Coolant supply external

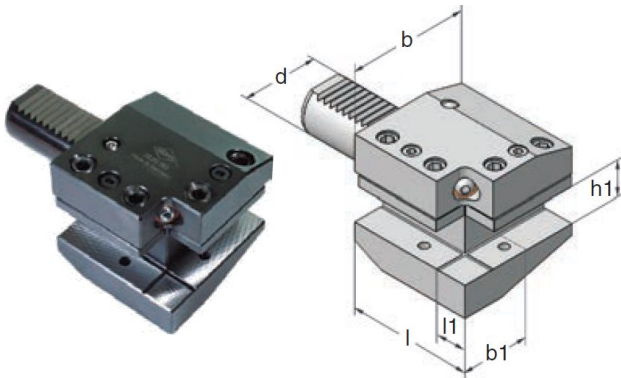

Art.-Nr.	Type	d	b	b1	h1	l	l1
20.16.160	B2/C2-20x16x	50	20	65	40.0	16	50
30.20.160	B2/C2-30x20x	70	30	72	39.0	20	70
50.32.160	B2/C2-50x32x120	50	105	55.0	32	120	25
60.32.160	B2/C2-60x32x135	60	125	62.5	32	135	30
40.25.160/170	B2/C2+B3/C3-40x25x100*						
*Double tooling							

We reserve the right to make technical changes.

Radial-axial toolholders form B3/C3

Coolant supply external

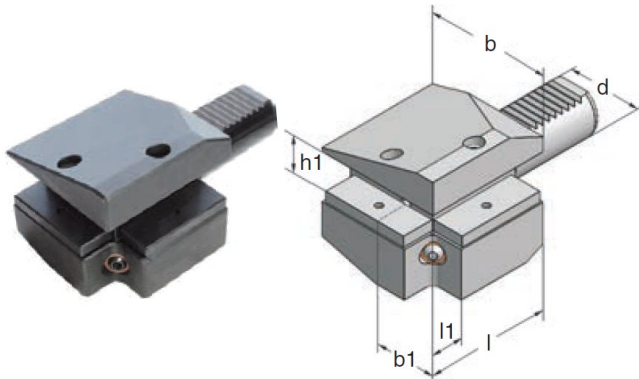

Art.-Nr.	Type	d	b	b1	h1	l	l1
30.20.170	B3/C3-30x20x	70	30	70	35.0	20	70 18
50.32.170	B3/C3-50x32x120	50	100	50.0	32	120	25
60.32.170	B3/C3-60x32x135	60	125	62.5	32	135	30
40.25.160/170	B2/C2+B3/C3-40x25x100*						
*Double tooling							

Radial-axial toolholders form B4/C4

Coolant supply external

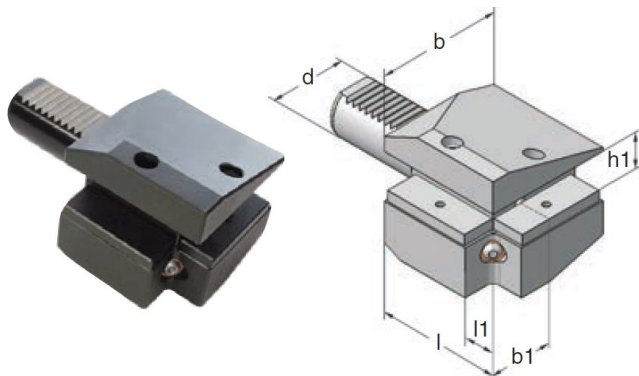

Art.-Nr.	Type	d	b	b1	h1	l	l1
30.20.180	B4/C4-30x20x	70	30	74	39.0	20	70 18
50.32.180	B4/C4-50x32x120	50	105	55.0	32	120	25
60.32.180	B4/C4-60x32x135	60	125	62.5	32	135	30
40.25.150/180	B1/C1+B4/C4-40x25x100*						
*Double tooling							

We reserve the right to make technical changes.