

Toolholders for CNC machines DIN 69880 / DIN ISO 10889

Toolholder blanks form A1

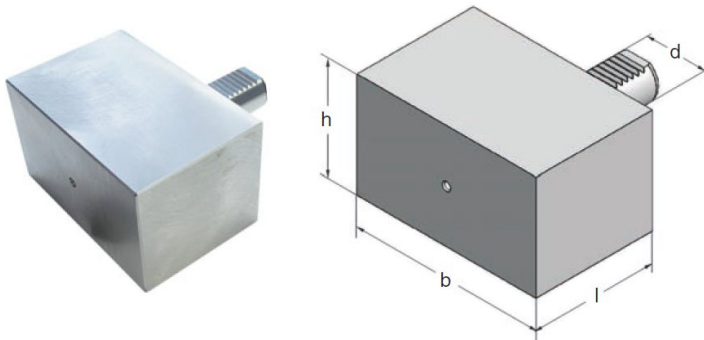

Special size on inquiry !

Art.-Nr.	Type	d	b	h	l
20.050.001	A1-20x 60	20	68	60	60
25.075.001	A1-25x 75	25	100	60	75
30.085.001	A1-30x 85	30	130	76	85
40.100.001	A1-40x100	40	156	96	100
50.125.001	A1-50x125	50	160	120	125
60.160.001	A1-60x160	60	165	125	160

Toolholder blanks form A2

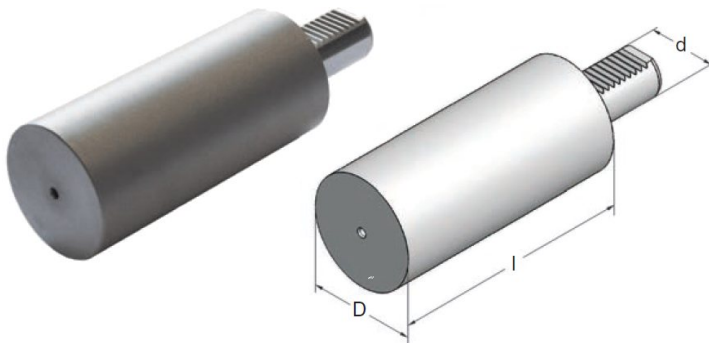

Special size on inquiry !

Art.-Nr.	Type	d	D	l
20.070.010	A2-20x 49x 70	20	49	70
25.080.010	A2-25x 58x 80	25	58	80
30.150.010	A2-30x 68x150	30	68	150
40.180.010	A2-40x 83x180	40	83	180
40.400.010	A2-40x 83x400	40	83	400
50.210.010	A2-50x 98x210	50	98	210
60.240.010	A2-60x123x240	60	123	240

We reserve the right to make technical changes.