

Toolholders for CNC machines DIN 69880 / DIN ISO 10889

Drill holders Whistle-Notch E1

Coolant supply internal + external

DIN 1835 Form E

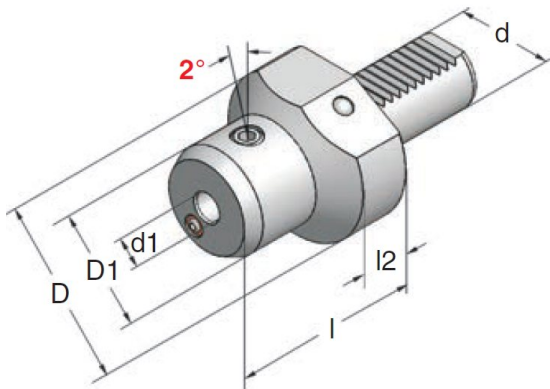

l1 = drill depth

Art.-Nr.	Type	d	d1	D	D1	l	l1	l2
20.06.221	E1-20x06Ex60	20	6	50	35	60	36	18
20.08.221	E1-20x08Ex60	20	8	50	35	60	36	18
20.10.221	E1-20x10Ex60	20	10	50	35	60	40	18
20.12.221	E1-20x12Ex60	20	12	50	44	60	45	18
20.14.221	E1-20x14Ex60	20	14	50	44	60	45	18
20.16.221	E1-20x16Ex60	20	16	50	50	60	48	-
20.18.221	E1-20x18Ex60	20	18	50	50	60	48	-
20.20.221	E1-20x20Ex60	20	20	50	50	60	50	-
30.06.221	E1-30x06Ex67	30	6	68	35	67	36	22
30.08.221	E1-30x08Ex67	30	8	68	35	67	36	22
30.10.221	E1-30x10Ex67	30	10	68	35	67	40	22
30.12.221	E1-30x12Ex67	30	12	68	44	67	45	22
30.14.221	E1-30x14Ex67	30	14	68	44	67	45	22
30.16.221	E1-30x16Ex67	30	16	68	52	67	48	22
30.18.221	E1-30x18Ex67	30	18	68	52	67	48	22
30.20.221	E1-30x20Ex67	30	20	68	52	67	50	22
40.06.221	E1-40x06Ex67	40	6	83	35	67	36	22
40.08.221	E1-40x08Ex67	40	8	83	35	67	36	22
40.10.221	E1-40x10Ex67	40	10	83	35	67	40	22
40.12.221	E1-40x12Ex67	40	12	83	44	67	45	22
40.14.221	E1-40x14Ex67	40	14	83	44	67	45	22
40.16.221	E1-40x16Ex67	40	16	83	52	67	48	22
40.18.221	E1-40x18Ex67	40	18	83	52	67	48	22
40.20.221	E1-40x20Ex67	40	20	83	52	67	50	22

We reserve the right to make technical changes.