

Toolholders for CNC machines DIN 69880 / DIN ISO 10889

Holders form F1 for M.T. shanks ISO 296

Coolant supply internal + external

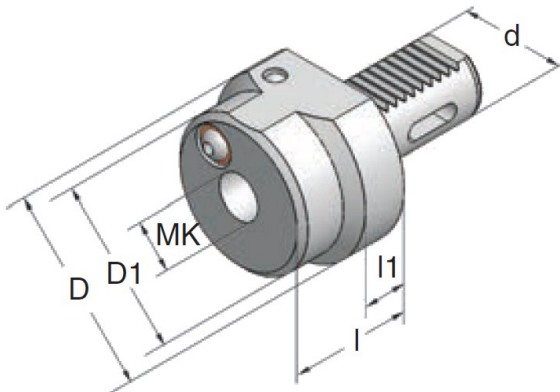

Art.-Nr.	Type	d	MK	D	D1	l	l1
20.01.200	F1-20xMK1x22	20	1	50	-	22	-
30.01.200	F1-30xMK1x25	30	1	68	52	25	25
30.02.200	F1-30xMK2x42	30	2	68	58	42	25
30.03.200	F1-30xMK3x66	30	3	68	68	66	-
40.01.200	F1-40xMK1x25	40	1	83	-	25	-
40.02.200	F1-40xMK2x34	40	2	83	58	34	25
40.03.200	F1-40xMK3x58	40	3	83	64	58	25
40.04.200	F1-40xMK4x86	40	4	83	72	86	25
50.02.200	F1-50xMK2x25	50	2	98	-	25	-
50.03.200	F1-50xMK3x42	50	3	98	64	42	25
50.04.200	F1-50xMK4x71	50	4	98	72	71	25
60.02.200	F1-60xMK2x27	60	2	123	-	27	-
60.03.200	F1-60xMK3x27	60	3	123	-	27	-
60.04.200	F1-60xMK4x55	60	4	123	72	55	25
60.05.200	F1-60xMK5x94	60	5	123	90	94	30

We reserve the right to make technical changes.