

Toolholders for CNC machines DIN 69880 / DIN ISO 10889

Quick locking drill chucks for left and right rotation

Coolant supply internal



Typ .13 + Typ .16

Coolant connection external

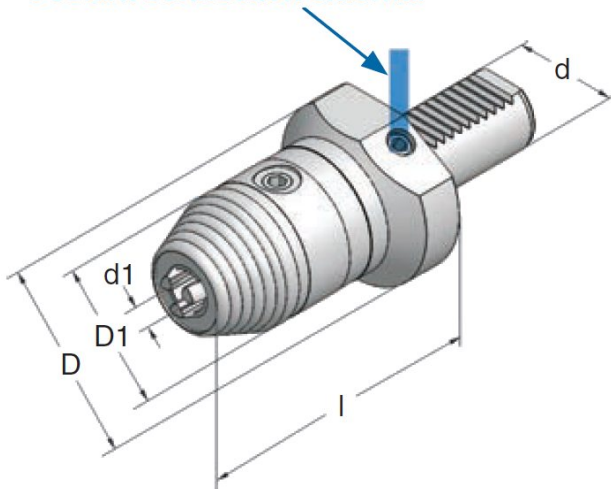

Art.-Nr.	Type	d	d1	D	D1	l
16.06.08	VDI16x1- 8x68	16	1- 8	44	36	68
20.06.08	VDI20x1- 8x68	20	1- 8	50	36	68
20.06.13	VDI20x1-13x96	20	1-13	68	50	96
25.06.08	VDI25x1- 8x68	25	1- 8	58	36	68
30.06.13	VDI30x1-13x96	30	1-13	68	50	96
40.06.13	VDI40x1-13x96	40	1-13	83	50	96
40.06.16	VDI40x3-16x96	40	3-16	83	57	96
50.06.16	VDI50x3-16x96	50	3-16	98	57	96
60.06.16	VDI60x3-16x96	60	3-16	123	57	96

We reserve the right to make technical changes.

Quick locking drill chucks
cylindrical shank

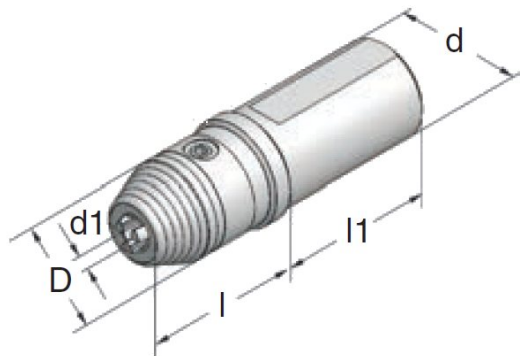

Art.-Nr.	Type	d	d1	D1	l	l1
25.08.13	zyl.25x1-13x74	25	1-13	50	74	55
30.08.13	zyl.30x1-13x74	30	1-13	50	74	55
32.08.13	zyl.32x1-13x74	32	1-13	50	74	55
40.08.13	zyl.40x1-13x74	40	1-13	50	74	68
40.08.16	zyl.40x3-16x74	40	3-16	57	74	68
50.08.13	zyl.50x1-13x74	50	1-13	50	74	88
50.08.16	zyl.50x3-16x74	50	3-16	57	74	88

We reserve the right to make technical changes.