

Toolholders for CNC machines DIN 69880 / DIN ISO 10889

**Radial toolholders Form B1
adjustable in height**

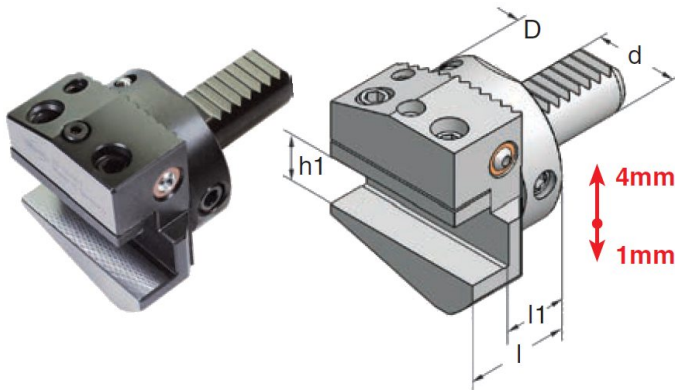

Art.-Nr.	Type	d	D	h1	l	l1
16.12.061	B1-16x12x34	16	36	12	34	23
20.16.061	B1-20x16x40	20	50	16	40	27
25.16.061	B1-25x16x45	25	58	16	45	32
30.16.061	B1-30x16x45	30	68	16	45	32

**Radial toolholders Form B3
adjustable in height**

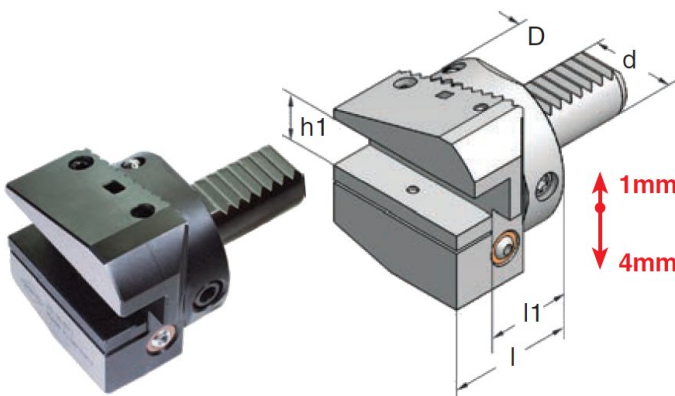

Art.-Nr.	Type	d	D	h1	l	l1
16.12.071	B3-16x12x34	16	36	12	34	23
20.16.071	B3-20x16x40	20	50	16	40	27
25.16.071	B3-25x16x45	25	58	16	45	32
30.16.071	B3-30x16x45	30	68	16	45	32

We reserve the right to make technical changes.

**Axial toolholders Form C1
adjustable in height**

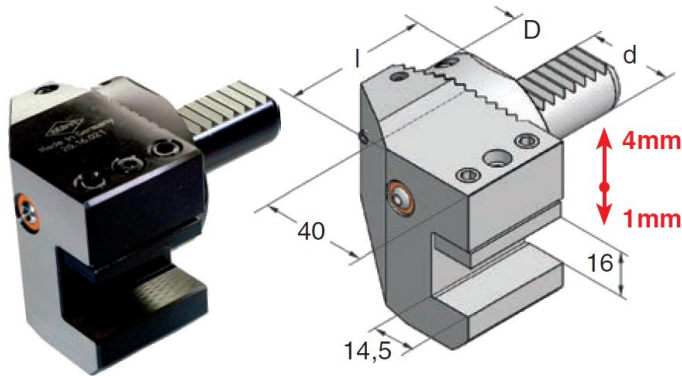

Art.-Nr.	Type	d	D	l
20.16.021	C1-20x16x50	20	50	50
25.16.021	C1-25x16x55	25	58	55
30.16.021	C1-30x16x55	30	68	55

**Axial toolholder Form C3
adjustable in height**

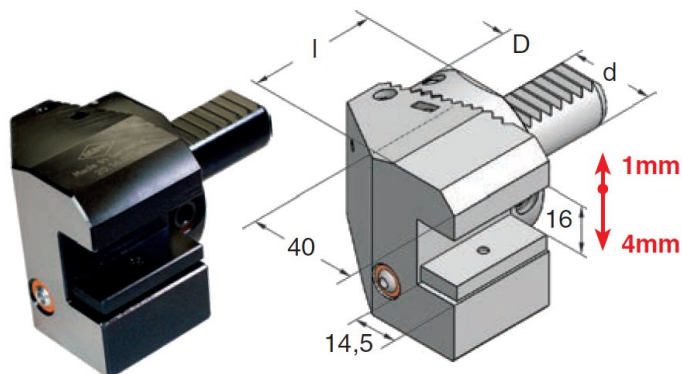

Art.-Nr.	Type	d	D	l
20.16.031	C3-20x16x50	20	50	50
25.16.031	C3-25x16x55	25	58	55
30.16.031	C3-30x16x55	30	68	55

We reserve the right to make technical changes.