



Toolholders for star-turret DIN 69880 / DIN ISO 10889

Double Turning toolholders form C1-C4

Double tooling

Delivery without tools

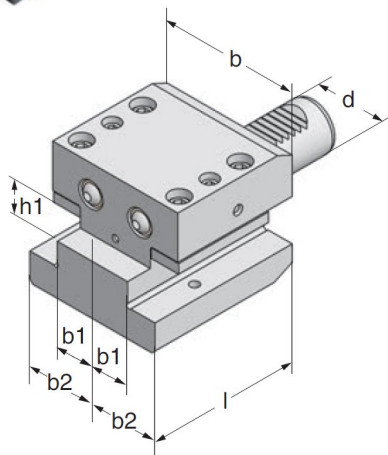

Art.-Nr.	Type	d	b	b1	b2	h1	l
30.20.042	VDI30D	30	88	26	44	20	90
40.25.042	VDI40D	40	95	25.5	47.5	25	90
INCH							
311208	VDI30D	30	90	23	45	1"	90
411208	VDI40D	40	95	25.5	47.5	1"	90

One turning-toolholder - four possibilities
left - right - forehead - overhead

Multi-double-turning-toolholder form C1-C4 with internal coolant

- for clamping holders with coolant channels directly to the cutting edge
- for ISO-clamping holders with claw clamping for best possible coolant supply

Delivery without tools

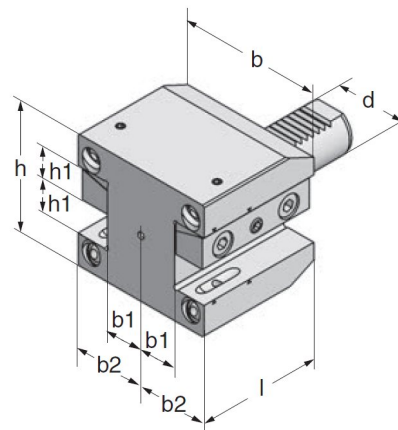

Art.-Nr.	d	b	b1	b2	h	h1	l
30.20.044	30	86	23	43	78	20	75
40.25.044	40	130	40	65	96	25	90

We reserve the right to make technical changes.