



Toolholders for star-turret DIN 69880 / DIN ISO 10889

Infeed toolholders right

Double tothing

Delivery without tools

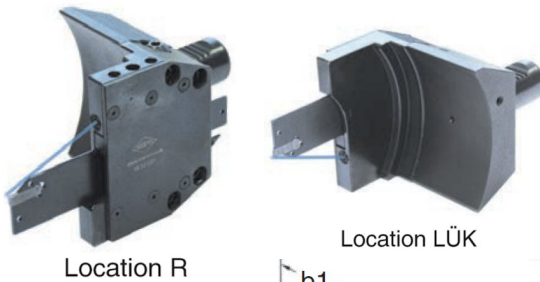

Location R

Location LÜK

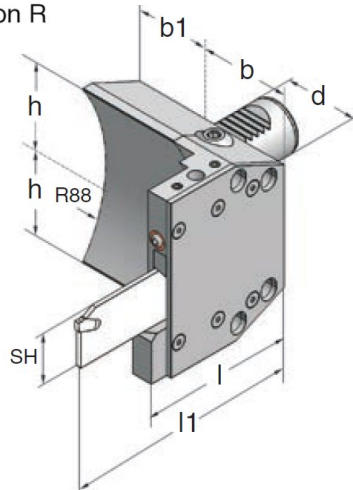

Art.-Nr.	Type	d	SH	b	b1	h	l	l1
25.26.485	VDI25Dx26R+LÜK	25	26	43	29	40	85	112
25.32.485	VDI25Dx32R+LÜK	25	32	43	29	40	85	112
30.26.485	VDI30Dx26R+LÜK	30	26	60	35	50	85	112
30.32.485	VDI30Dx32R+LÜK	30	32	60	35	50	85	112
40.32.485	VDI40Dx32R+LÜK	40	32	60	35	50	88.5	115

Infeed toolholders right

Adjustable in height $\pm 0.5\text{mm}$

Delivery without tools

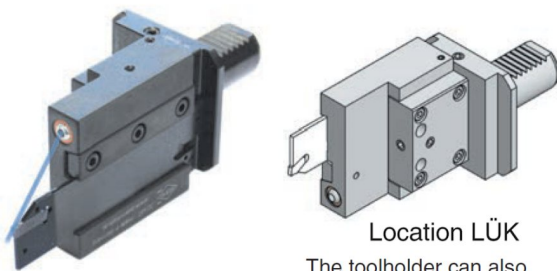

Location LÜK

The toolholder can also

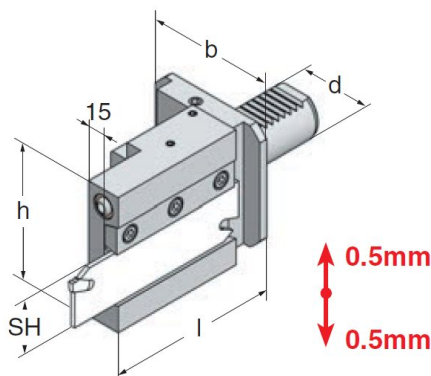

Location R

We reserve the right to make technical changes.

Art.-Nr.	Type	d	SH	b	h	l
30.26.487	VDI30x26R+LÜK	30	26	70	78	95
30.32.487	VDI30x32R+LÜK	30	32	70	78	95
40.32.487	VDI40x32R+LÜK	40	32	70	78	95

Toolholders for star-turret DIN 69880 / DIN ISO 10889

Infeed toolholders left

Double tooling

Delivery without tools

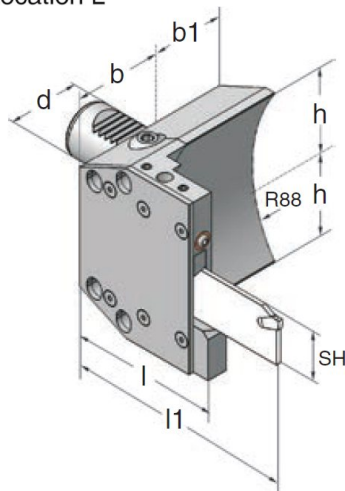
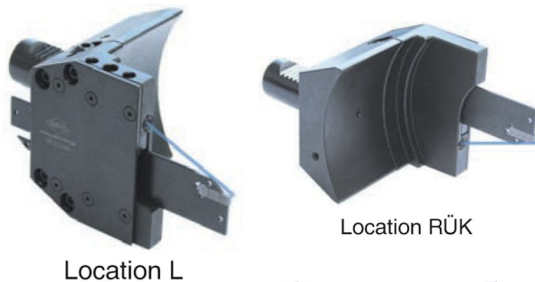

Art.-Nr.	Type	d	SH	b	b1	h	l	l1
25.26.486	VDI25Dx26L+RÜK	25	26	43	29	40	85	112
25.32.486	VDI25Dx32L+RÜK	25	32	43	29	40	85	112
30.26.486	VDI30Dx26L+RÜK	30	26	60	35	50	85	112
30.32.486	VDI30Dx32L+RÜK	30	32	60	35	50	85	112
40.32.486	VDI40Dx32L+RÜK	40	32	60	35	50	88.5	115

Infeed toolholders left

Adjustable in height $\pm 0.5\text{mm}$

Delivery without tools

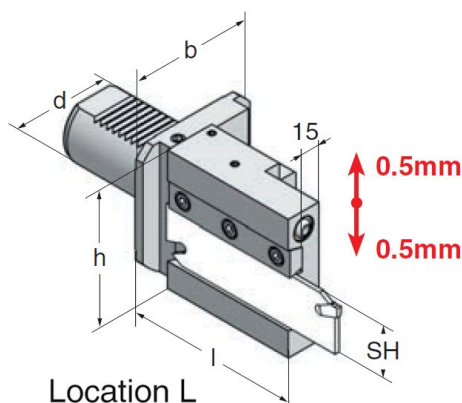
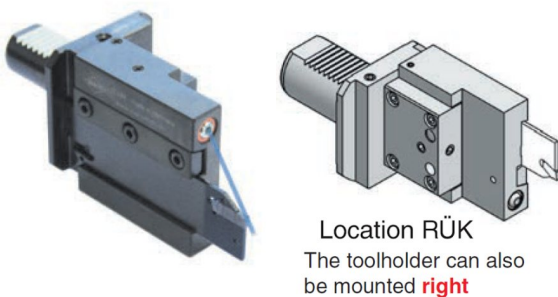

Art.-Nr.	Type	d	SH	b	h	l
30.26.488	VDI30x26L+RÜK	30	26	70	78	95
30.32.488	VDI30x32L+RÜK	30	32	70	78	95
40.32.488	VDI40x32L+RÜK	40	32	70	78	95

We reserve the right to make technical changes.